

## TECHNICAL DATA SHEET MIV Loft Mounted Unit | Whole House Positive Input Ventilation Unit



Lifetime Range®

### PRODUCT

Whole house multiple input ventilation system for properties with a loft space.

### APPLICATIONS

Sited in a loft space, the unit delivers air to multiple rooms of a property to provide displacement ventilation in order to improve indoor air quality and resolve condensation related problems.

### SERVICING / MAINTENANCE

Achieved by removal/exchange/replacement of filters and consumable items. There should be no requirement for any maintenance within the five year period.

### ACCREDITATIONS

- Conforms to the requirements of the UK Building Regulations and the Technical Standards for Ventilation
- Conforms to requirements of the EC council directives
- Relating to Electromagnetic Compatibility and Electrical Safety (LDV and EMC). CE Marked

### INTEGRAL 'INTELLIGENT LOW TEMPERATURE' COMFORT HEATER

Powered by a single supply and capable of holding incoming air temperatures accurately - around 10°C. The integral heater element is manufactured in a solid tubular sheath material and not in open wire format.

### PERFORMANCE & SOUND LEVELS

Incoming Air Temp. (°C)	Fan Speed Setting	Specific Fan Power (SFP)	Airflow (l/s)	Power Usage (W) (4)	Outlet Noise dB(A) @3m
<19 (1) (2)	Trickle	0.24	15	4	<15
	Medium	0.22	20	4	<15
	Large	0.21	26	6	<15
	Boost	0.25	34	9	<15

## TECHNICAL DATA SHEET MIV Loft Mounted Unit | Whole House Positive Input Ventilation Unit

### INSTALLATION

Full installation guide is enclosed with all products; or sent separately in advance - if required.

### CONSTRUCTION

ABS plastic to contain at least 50% recycled material.

### MOTOR

Incorporates the Ultra Low Watt DC motor technology with sealed for life ball bearings designed to operate continuously at a pre-set 'background' rate.

### FAN

Is a 140 x 220mm centre mounted forward curved centrifugal fan.

### FILTER

Is a synthetic fibre based filter made to ISO Coarse 65% (G4) standard in accordance with EN779 standard ratings. The filter should conform to all European Union and US fire classification standards (e.g. DIN 53438-F1 and UL900-class 2) and be self-extinguishing.

### WARRANTY

Covered by an on-going, repeatable 5 year warranty, subject to the completion of specified maintenance.

### SIZE (MM)

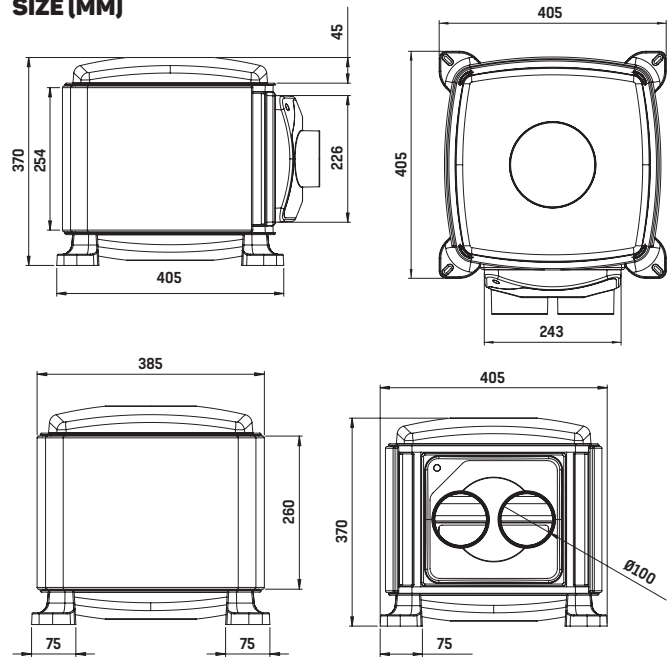

### PERFORMANCE CURVE

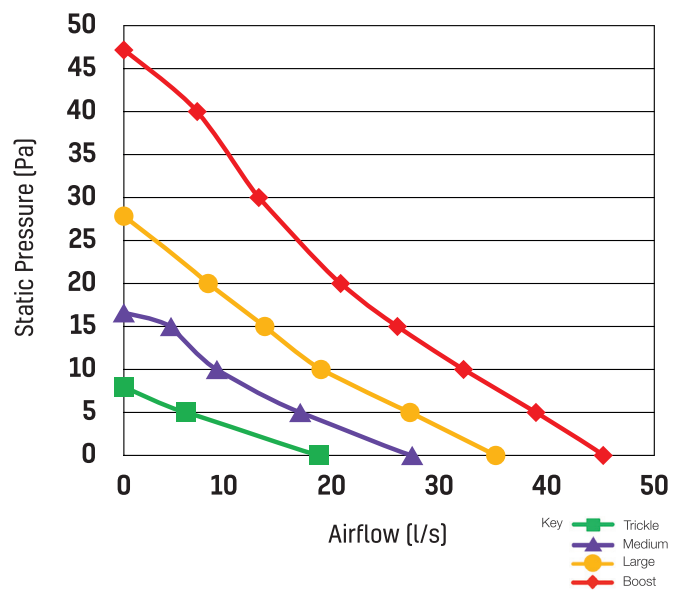

A full Consultant Specification can be sent on request.