



Wall Mounted Unit

INSTALLATION AND USER GUIDE





Made in Harrogate
UK

Thank you for choosing EnviroVent

The fastest growing ventilation company in the UK.

You are about to install a product that is designed to outlast the life-cycle of the building. Once installed the unit will operate continuously for 5 years and beyond without a major service. Please therefore ensure that this product is treated with care and installed properly i.e. for the life of the building. If the unit is mishandled you might break it! This invalidates the warranty.

And remember, if you have any problems please call our dedicated Technical Team. We are always pleased to help and in an emergency will come out to site quickly, completely free of charge.

HOTLINE: 0845 27 27 810

PRE-INSTALLATION CHECKLIST

OBJECTIVE

The EnviroVent Wall Mounted Unit should be positioned on an external wall to deliver air to the centre of the dwelling through ducting bends and grilles.

- 1 Choose the position of the unit and establish that the route of ductwork is free from obstruction i.e. cables/pipes etc.
- 2 Check that the air intake is not within 3m above a boiler flue outlet or within 1m if to the left, right or below.
- 3 Ensure that the duct run is kept as straight as possible.
- 4 Ensure that rigid duct is used throughout the installation.
- 5 Ensure that the air supply is central in the dwelling (i.e. central hallway) and is as high as possible.
- 6 Ensure that the duct runs are no more than 10m long.
- 7 Keep the core hole 150mm away from a window reveal.

IMPORTANT

Be sure to have read and understood these instructions before beginning the installation process

SAFETY AND RECOMMENDATIONS

All wiring must comply with Building Regulations and the current I.E.E. Wiring Regulations (BS7671) or the equivalent standards for your country. The final installation should be examined and tested by a qualified electrician. This appliance is not intended for use by any person with reduced physical, sensory or mental capabilities, or lack of experience and knowledge, unless they have been given supervision or instruction concerning use of the appliance by a person responsible for their safety. Children should be supervised to ensure that they do not play with the appliance. If the supply cord is damaged, it must be replaced by the manufacturer, its service agent or similarly qualified persons in order to avoid a hazard.

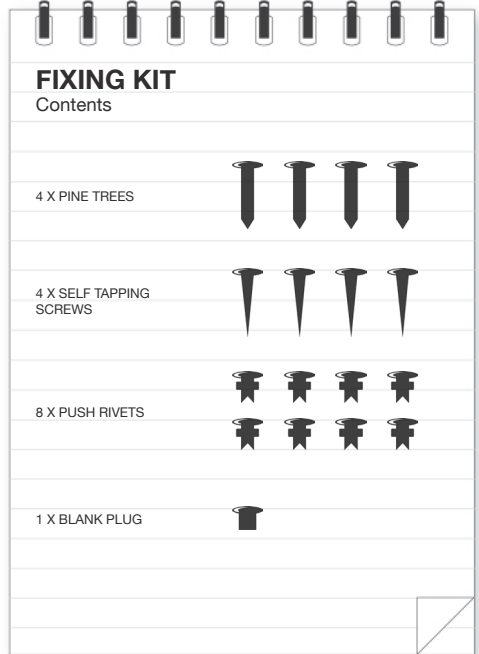

**DO NOT REMOVE OR TAMPER
WITH ELECTRONIC CIRCUIT
BOARD**

This is not a user function.

SHOULD YOU ENCOUNTER ANY PROBLEMS INSTALLING THIS UNIT CALL

0845 27 27 810

envirovent

INSTALLATION DIAGRAMS

STANDARD INSTALLATION



VIEW OF WHOLE UNIT ASSEMBLED

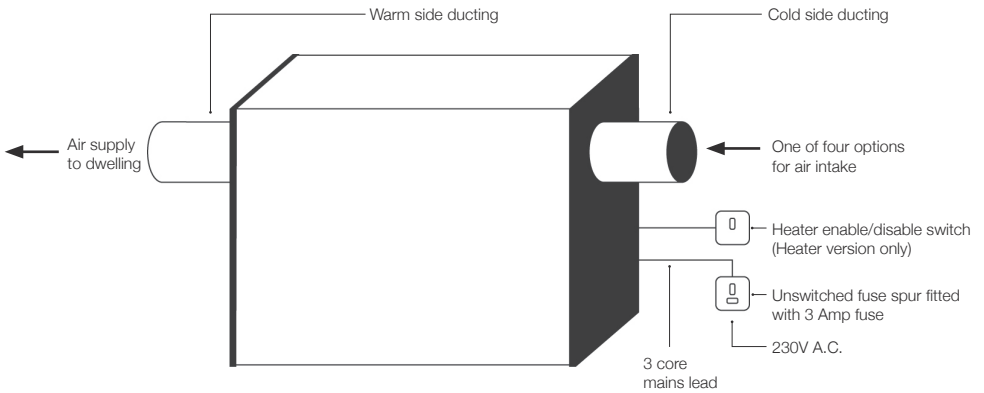

UNIT DIMENSIONS

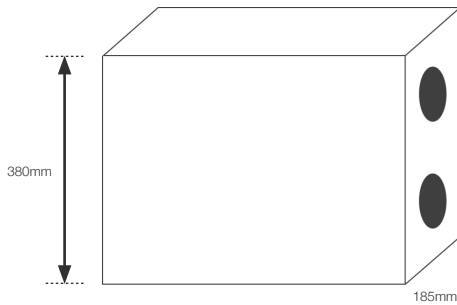

SHOULD YOU ENCOUNTER ANY PROBLEMS INSTALLING THIS UNIT CALL

0845 27 27 810

INSTALLATION INSTRUCTIONS

FIRST STAGE

1. Choose the desired position of the EnviroVent Wall Mounted Unit using the pre-installation check list.
2. Decide if the installation required is a left-handed or right-handed unit. This can be determined by using the back panel (figure 1, option 1 or 2) and the central carcass (figure 2).

Fig. 1

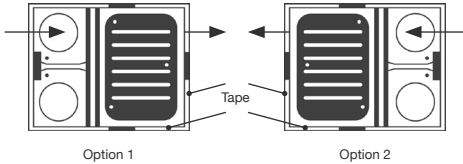
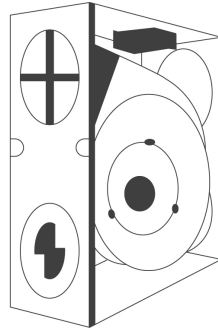

Figure 1: Back panel showing direction of air flow

Fig. 2



Central Carcass

SECOND STAGE

1a. If the air intake is through the side panel, it is necessary to use end panel A (figure 3) as a template by removing the knock out, ensuring the cable exit is closest to the wall. Mark up the wall. Ensure that you leave enough space around the template for the unit and panels to fit.

OR

1b. If the air intake is through the back panel it is necessary to use the assembled back panel/central carcass as a template and mark up the wall. Ensure that you leave enough space around the template for the unit and panels to fit (figure 4).

Fig. 3

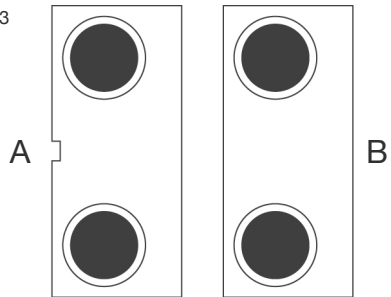

Figure 3a
End panel with cable outlet

Figure 3b
End panel

THIRD STAGE

1. Drill a hole with a 107mm core in the marked position. If the air intake is through the end panel A, cut a length of ducting* that equals the thickness of the outer wall plus 80mm. If the air intake is through the back panel, cut a length of ducting* that equals the thickness of the outer wall plus 15mm.

2. Insert the duct* into the hole through the outer wall and attach the outer grille*.

*Duct, ducting and grilles are not included with the EnviroVent Wall Mounted Unit.

Fig. 4

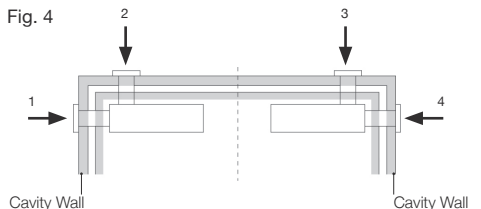

INSTALLATION INSTRUCTIONS

T-PIECE

There will be some occasions where it is necessary to fit a T-piece to the EnviroVent Wall Mounted Unit. This will be due to the dwelling having a remote kitchen/bathroom away from the central hallway which will not directly benefit from the air supply being delivered to the zone.

PLAN VIEW



COLD SIDE DUCTING

Due to the layout of some properties, there may be occasions where it is necessary to install the EnviroVent Wall Mounted Unit in a central position within the dwelling i.e. away from the external wall surface. This will result in a length of "cold side ducting" being installed between the external wall and the unit, running through the dwelling.

In the event of "cold side" ducting being required, an insulated sleeve should be used to ensure condensate does not form on its surface. To improve the aesthetic appearance of this ducting, we recommend that it is boxed in on completion of the installation.

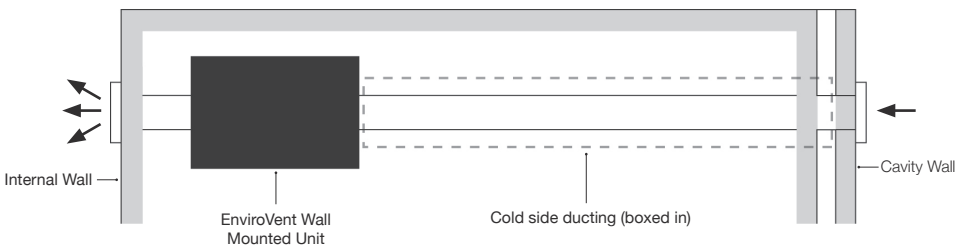

AFTER SALES SERVICE

We recommend you do not dismantle or remove any other parts than those mentioned, as any tampering would automatically cancel the guarantee. If you detect any fault, contact EnviroVent on 0845 27 27 810.

MAINTENANCE

Should be achieved by replacement of filters and consumable items. There should be a filter exchange after 3 years.

USER GUIDE

About Wall Mounted Unit

DO YOU KNOW WHAT'S GOING ON IN YOUR OWN HOME?



MOISTURE

The typical household creates around 100 pints per week - from showers, baths, cooking etc.



CHEMICAL EMISSIONS

From everyday household furnishings, building products etc.



FUMES

From tobacco products, exhaust gases etc.



DUST

From furniture, carpets, bedding etc.

= Poor Air Quality = Condensation, Damp & Mould

THE CAUSE OF CONDENSATION, DAMP AND MOULD

In a dwelling of 4 people, each will contribute approximately 4 pints of moisture per day – through showers, boiling kettles, cooking etc totalling over 100 pints of liquid per week.

Other airborne contaminants which exist in a typical dwelling like dust, tobacco products, exhaust gases – even chemical emissions from furnishing and building products further deteriorate air quality.

In older, less energy efficient dwellings, there is a natural escape for this hot, damp problem air – through ill-fitting windows and doors, uncarpeted floorboards, lofts without insulation and so forth.

Improved building features such as cavity wall insulation, double-glazing and draft proofing prohibit 'natural ventilation'. Stale, humid air is trapped – increasing the condensation problem in the dwelling.

The Benefits

Say goodbye to condensation & mould

- Whole house ventilation
- Improved air quality
- Musty odours removed
- Streaming windows stopped
- Condensation control
- Enhanced heat distribution
- Benefits allergy and asthma sufferers

SHOULD YOU ENCOUNTER ANY PROBLEMS INSTALLING THIS UNIT CALL

 0845 27 27 810

How does my Wall Mounted Unit work?

The Wall Mounted Unit work by supplying fresh, filtered air throughout the home to transform a stagnant and stale atmosphere into a fresh, healthy and condensation-free environment. The Wall Mounted Unit delivers air into a home via a single input, usually located in a central hallway.

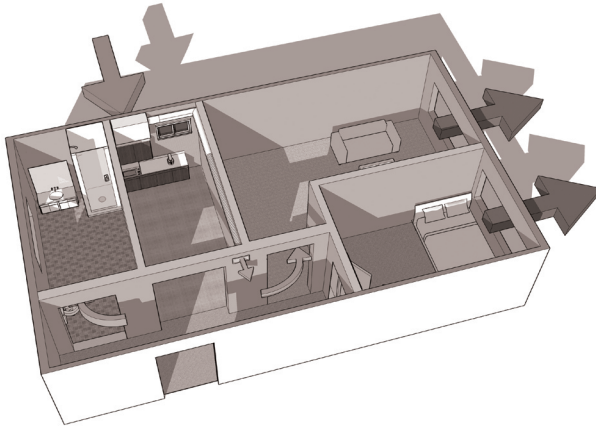

How does my Wall Mounted Unit help?

It prevents the build-up of moisture in the house, controlling steam/condensation during bathing and cooking to prevent the formation of black mould on walls, behind cupboards etc. It will also help to stop general dampness and musty smells caused by poor ventilation.

Energy Saving Benefits

Your Wall Mounted Unit also helps to save energy in the following ways:

Minimum Energy Consumption

- ✓ Using the latest technology, the units are powered by ultra-low watt motors to achieve low running costs.

Heat Distribution

- ✓ Warm air accumulates at ceiling level. This air can be up to 7°C higher than the internal air at ground level. By introducing an air supply, the Wall Mounted Unit helps to redistribute heat around the home to further reduce heating costs.

No need to open windows

- ✓ To reduce humidity and condensation during the heating season, significant energy loss occurs by opening windows. The Wall Mounted Unit provides fresh, filtered air to the home and reduces humidity without the need to open windows, saving energy and heat loss.

Health Benefits:

- ✓ Reduces mould spores, a trigger for respiratory problems and allergies.
- ✓ Reduces house dust mite populations by lowering humidity levels - a main trigger for asthma and allergies.

How do I control my Wall Mounted Unit?

Standard automatic mode: On auto the flow rate of the unit will be set at the appropriate level for your home during installation. To enable or disable the heater press the heater enable switch on or off.

What features does my Wall Mounted Unit have?

The intelligent low temperature comfort heater* is designed to temper the air during periods of low external temperatures. It is capable of holding incoming air temperatures accurately at 10°C. With the function enabled, the heater may be on 10% of the time, depending on the fan speed setting and only at loft temperatures at or below 10°C. The unit has an automatic increased airflow setting. This function increases airflow rates per setting by 10% to deliver additional air into the property at temperatures above 19°C.

*Heater may be omitted on request by the customer.

Maintenance

After 3 years the filter located in the unit must be replaced. Screws located on the edge of the cover must be removed and the cover loosened and removed. Pull on the foam pad on the side of the unit to remove the filter. Replace the filter and covers ensuring all duct work is securely in place. Work to be carried out by a technically competent person. When carrying work out to this unit it should be isolated from the main power supply at the fuse spur.

How much does my Wall Mounted Unit cost to run?

The Wall Mounted Unit is very energy efficient. On a constant medium setting with the heater enabled, the unit will cost around £30* a year to run. With the heater disabled the unit will cost less than £6* a year.

*Based on an average electricity unit price of 15p.
Costs will vary year on year depending on atmospheric conditions and unit settings.

Helpful hints and tips

Keeping your home condensation free:

- Try to keep the house as warm as possible for as long as possible
- Do not dry clothes over any radiators
- Vent your tumble dryer outside
- Do not use paraffin / Calor gas type heating

Energy bills:

- To minimise energy bills you may need to adjust the central heating down if the input is in the same room as your thermostat.

WARRANTY CONDITIONS AND EXCLUSIONS

The Wall Mounted Unit is covered by a 5 year warranty.

Do not turn your unit off. It is important that the unit runs continuously.

EnviroVent offer customers a full Supply and Fit service. This service also entitles our customers a unique 5 years parts and labour guarantee and if within the 5 years of installation the unit breaks down, we will repair it – FREE of charge.

Should you buy the fan from an approved wholesaler the product is protected by a 5 years parts guarantee and in the highly unlikely event of any problems you can call our helpline number or return it to the approved wholesaler.

Please note that proof of purchase by the way of a receipt is required and that any fans bought from an unapproved source, including but not limited to Ebay, will render the guarantee invalid.

What should I do if I have a problem?

If, after thoroughly reading this booklet, you feel that your unit is not working correctly, you can telephone the number shown at the bottom of this page (operational from 8:30am to 5:30pm Monday to Friday), and ask for technical assistance.

Serial number of the unit.....

We appreciate you choosing this quality EnviroVent product, which is designed and manufactured to the highest specification in Harrogate, North Yorkshire. We are confident that you will be delighted with the performance of the system and the resulting improvement in air quality in your home after the installation of the unit.

However, it is important that you register your purchase (see overleaf). This will ensure the prompt and efficient handling of any communication in the event that your unit requires attention during the 5 year warranty period.

Your warranty covers any defect or break down that arises due to faulty materials or construction.

- The system must be correctly installed and operated according to the instructions contained in the user guide supplied.
- Periodic cleaning and maintenance must be carried out by a technically competent person.
- The warranty will be rendered invalid if the unit is turned off. Turning the unit off can damage it.
- The warranty does not cover accidental damage, misuse or abuse.
- The warranty is in addition to your statutory or legal rights.
- The warranty will only be honoured from approved suppliers.
- A further 5 year warranty can be obtained subject to the level of service carried out at the 5 year point.



Wall Mounted Unit
REGISTRATION FORM AND 5 YEAR WARRANTY

Our Warranty Statement
 If within 5 years of installation, the unit breaks down, we will repair it - free of charge.

Please sign and return this form to register your warranty.

Dear Customer,

You have a Wall Mounted Unit installed in your home. It is designed to give you many years of trouble free use and will improve the air that you and your family breathe as well as curing condensation, mould and other poor indoor air problems.

Nothing on this form will affect your statutory rights.

Name of occupier:	Date of installation:
Address of property:	Type of unit installed:
.....	Serial number of unit:
Postcode:	Type of property (detached etc):
Signature:	Telephone number (if available):

Delivering innovative and sustainable
 ventilation solutions worldwide

 Please read carefully to ensure simple installation and a long trouble free life for the user.

AFTER INSTALLING THIS FAN PLEASE PASS ONTO END USER - DO NOT THROW AWAY

EnviroVent Ltd
 EnviroVent House
 Hornbeam Business Park
 Harrogate
 HG2 8PA

T 01423 810 810
 F 01423 810 910
 E info@envirovent.com

www.envirovent.com



E&OE | MKT ENV241-V3-01.05.13

Due to our policy of continuous innovation and improvement EnviroVent reserves the right to alter products specification and appearance without notice.