

Wall Mounted Unit



Whole House Positive Input Ventilation Unit



Energy Saving Benefits

✓ Minimum Energy Consumption

Powered by an Ultra Low Watt Brushless Motor, the EnviroVent Wall Mounted Unit utilises the latest technology to ensure minimum energy consumption and long term trouble free life.

✓ Heat Distribution

Warm air accumulates at ceiling level. This air can be up to 7°C higher than the internal air at ground level. By introducing an almost imperceptible air supply into the dwelling, the EnviroVent Wall Mounted Unit helps to redistribute heat around the home and thus reduce space heating costs.

✓ No Need To Open Windows

To reduce humidity and condensation during the heating season, significant energy loss occurs by opening windows. By installing an EnviroVent Wall Mounted Unit and providing fresh filtered air into the home, humid air is displaced without the need to open any windows, thus making significant savings to the occupier.



About

The EnviroVent Wall Mounted Unit is designed to provide whole home ventilation and eradicate condensation from homes without a loft space. Energy efficient, the unit introduces an almost imperceptible air supply throughout the living space to transform a stagnant and stale atmosphere into a fresh, healthy and condensation free environment.

features & benefits

- Ultra Low Watt DC motor technology
- Integral Hours Run Meter (as standard)
- Integral Pre-Heater (as standard)
- 5 year guarantee
- Reduces/eliminates surface condensation
- Quiet operation
- Eliminates mould
- Stops streaming windows
- Removes musty odours
- Improves air quality
- Enhances heat distribution
- Benefits asthma sufferers
- BBA approved
- Expert fitting staff

Health Benefits



With improved building features in our homes, such as cavity wall insulation, double glazing and draught proofing, 'natural ventilation' is prohibited. Stale air is trapped causing streaming windows, which ultimately leads to musty smells, dampness and mould growth. These mould spores are known allergens and become airborne at the slightest disturbance. The microscopic spores are then inhaled

and can trigger respiratory problems such as asthma, dust allergies and hay fever. The EnviroVent Wall Mounted Unit draws fresh air into the dwelling from outside and filters it before being delivered into the property. Moisture laden air is diluted, displaced and replaced with clean, tempered and filtered air. This eliminates or reduces surface condensation, which causes mould growth, providing a significant improvement in the health of asthma sufferers and general indoor air quality.



EnviroVent Ltd
EnviroVent House
Hornbeam Business Park
Harrogate
HG2 8PA
01423 810 810
info@envirovent.com
www.envirovent.com

envirovent

Life-Cycle Costs

With 5 year on-going warranties and superior long life filters the unit achieves the lowest life-cycle costings.

Once installed, there is no requirement for any maintenance within the first two years, after which the air quality filter should be cleaned or replaced.

All other component replacement is carried out simply and quickly by exchanging the consumable items.



The worn out components are then taken back to the factory to be recycled thus reducing the impact on landfill and saving millions of pounds in replacement costs.

Pre-Heater and Hours Run Meter

The integral pre-heater is designed to temper the incoming air during periods of low external temperatures.

A sensor monitors incoming air and pulses the heater to ensure temperatures are held to pre-set minimums.

Two independent safety cut-out devices shut down the heater in the event of fan failure. The heater facility is controlled independently from the fan by a conveniently positioned enable/disable switch.

For monitoring of operational life and verification of usage, an integral Hours Run Meter is fitted.

Dimensions (mm)

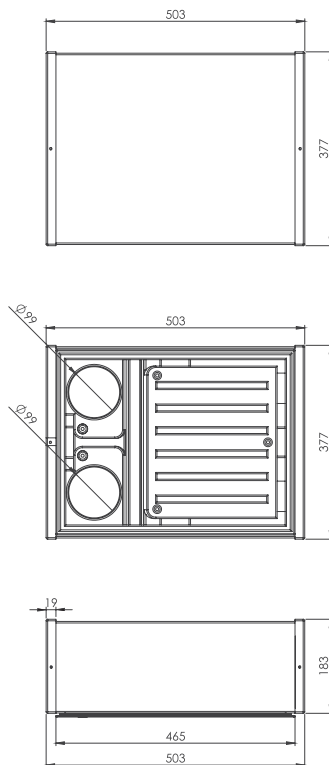

Technical Specifications

Product

Whole house positive input ventilation system for apartments and flats.

Applications

Sited on a suitable wall, the EnviroVent Wall Mounted Unit delivers air to the central hallway to provide displacement ventilation in order to improve air quality and resolve condensation related problems.

Performance & Sound Levels (as installed figures)

Incoming Air Temp. (°C)	Fan Speed Setting	Specific Fan Power SFP	Airflow (l/s)	Power Usage (W)	Outlet noise dB(A) @ 3m
<19 ⁽¹⁾	Trickle	0.39	9	3.4	<15
	Medium	0.33	11	3.8	<15
	Large	0.29	17	4.8	17
	Boost	0.30	20	6.1	20.3
>19 ⁽²⁾	Trickle	0.37	10	3.6	-
	Medium	0.33	14	4.4	-
	Large	0.29	19	5.4	-
	Boost	0.32	23	7.4	-

(1) The unit performs in 'condensation control mode' at air temperatures below 19°C

(2) At above 19°C the unit increases airflow rates per setting by 10%

Installation

Full installation guide is enclosed with all products; or sent separately in advance - if required.

Motor

Incorporates the Ultra Low Watt DC motor technology with sealed for life ball bearings designed to operate continuously at a pre-set 'background' rate.

Fan

Is a 140 x 220mm centre mounted forward curved centrifugal fan.

Filter

Is fitted with an integral insect filter.

Servicing / Maintenance

Achieved by removal/exchange/replacement of filters and consumable items. There should be a filter exchange after 24-36 months.

Guarantee

Covered by an on-going, repeatable 5 year warranty, subject to the completion of specified maintenance.

Integral 'Intelligent Low Temperature' Comfort Heater

Powered by a single supply and capable of holding incoming air temperatures reasonably accurately – around 10°C. The heater element is manufactured in a solid tubular sheath material and not in open wire format.

Accreditations

This product is in conformity with the European Low Voltage Directive 2006/95/EEC and the EMC Directive 2004/108/EC including amendments. Full compliance with the relevant parts of the standards listed below supports the conformity of the designated product with the provisions of the above mentioned EC Directives.

Low Voltage Directive

EN 60335-1:2002, +A1:2004, +A2:2006, +A12:2006, +A13:2008, +A14:2010

EN 60335-2-60:2003, +A1:2004, +A2:2009

EMC Directive

EN55014-1:2006 (EMISSIONS)

EN55014-2:1997, +A1:2001 Cat IV (IMMUNITY)

BBA

Certificate No: 03/4043

Annual Running Costs

Annual running cost with heater DISABLED. All costs are based on an electricity cost of £0.15 per unit (kWh). These calculations must be used as a guide only. Below are comparisons against other household appliances

Settings

Trickle	Medium
£4.47	£5.00

Household Appliance	Time required to consume £5.00 of electricity
Fridge Freezer	17 Days
21" TV (Viewing Time)	13 Days
100W Light Bulb	12.5 Days
Home Computer	4 Days
Games Console	4 Days
Iron	41 Hours
Tumble Dryer	17 Hours
Coldfill Dishwasher	15 Loads

Performance Curve

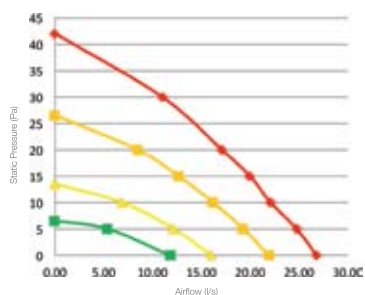

Performance curve results are based on the unit running below 19°C and exclude ancillaries

Key	Trickle	Medium	Large	Boost
■	■	■	■	■

Order Code

EVF-H

Wall Mounted Unit with heater